

FEATURES

- **Standard 6.0mm x 3.5mm Ceramic Surface Mount Package**
- **Fundamental Crystal Design**
- Frequency Range 8 – 50 MHz
- Frequency Tolerance, ± 30 ppm Standard
[other tolerances available]
- Frequency Stability, ± 50 ppm Standard
[other stabilities available]
- Operating Temperature to -40°C to $+85^{\circ}\text{C}$
- Stable Frequency Over Temperature and Drive Level
- Tape & Reel Packaging Standard, EIA-481
- **RoHS/Green Compliant (6/6)**



APPLICATIONS

The Model 406 is a seam sealed ceramic packaged crystal offering reduced size, ideal for high-density circuit board applications. M406 offers reliable precision and excellent shock performance suitable for wireless communications, broadband access, WLAN/WiMax/WIFI, portable equipment, test and measurement, PCMCIA, computers and modems.

ORDERING INFORMATION

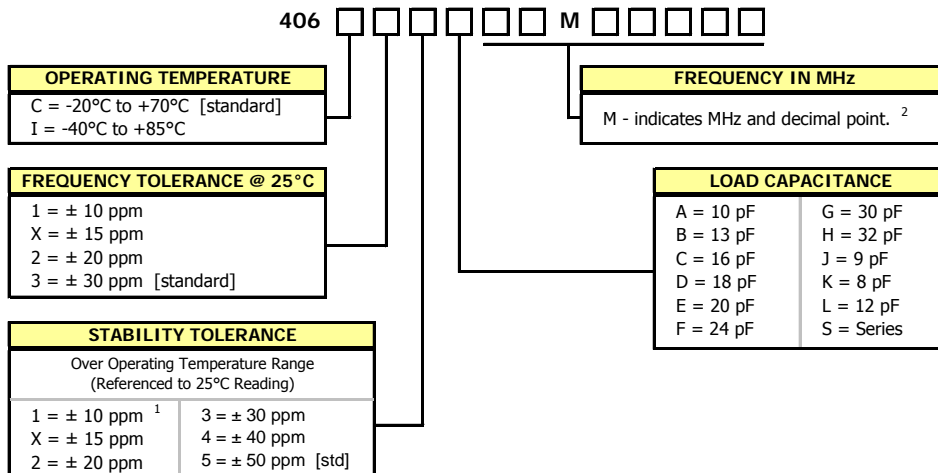

1] Only available with temperature range code "C".

2] Frequency is recorded with two leading digits before the 'M' and 5 significant digits after the 'M' (including zeros).

[Ex. XXMXXXX (16M38400), XXMXXXX (14M31818)]

**Not all performance combinations and frequencies may be available.
Contact your local CTS Representative or CTS Customer Service for availability.**

PACKAGING INFORMATION [reference]

Device quantity is 1k pcs. maximum per 180mm reel.

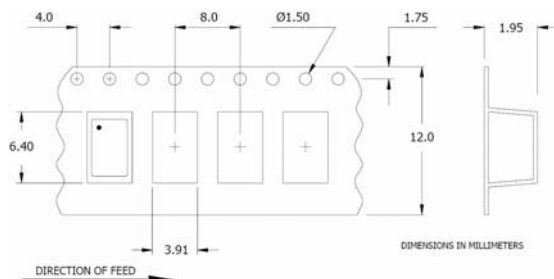

ELECTRICAL CHARACTERISTICS

	PARAMETER	VALUE
ELECTRICAL PARAMETERS	Frequency Range	8.0 MHz to 50.0 MHz
	Operating Mode	Fundamental
	Crystal Cut	AT-Cut
	Frequency Tolerance @ 25°C	± 30 ppm standard [± 10 ppm, ± 15 ppm and ± 20 ppm Available]
	Frequency Stability Tolerance [Operating Temperature Range, Referenced to 25°C Reading]	± 50 ppm standard [± 10 ppm, ± 15 ppm, ± 20 ppm, ± 30 ppm and ± 40 ppm Available]
	Operating Temperature Range	-20°C to +70°C -40°C to +85°C
	Equivalent Series Resistance	See ESR Table
	Load Capacitance or Resonance Mode	See Ordering Information
	Shunt Capacitance (C ₀)	4.0 pF typical 7.0 pF maximum
	Drive Level	10 µW typical 100 µW maximum
	Aging @ +25°C	±3 ppm/yr typical ±5 ppm/yr maximum
	Insulation Resistance	500M Ohms @ 100V _{DC} ±15V _{DC}
	Storage Temperature Range	-55°C to +125°C
	Reflow Condition, per JEDEC J-STD-020	+260°C maximum, 10 Seconds maximum

EQUIVALENT SERIES RESISTANCE TABLE

FREQUENCY RANGE	MODE of OSCILLATION	ESR Maximum
8.00 MHz - 9.999 MHz	Fundamental	80 Ohms
10.00 MHz - 15.999 MHz	Fundamental	60 Ohms
16.000 MHz - 50.000 MHz	Fundamental	40 Ohms

MECHANICAL SPECIFICATIONS

PACKAGE DRAWING

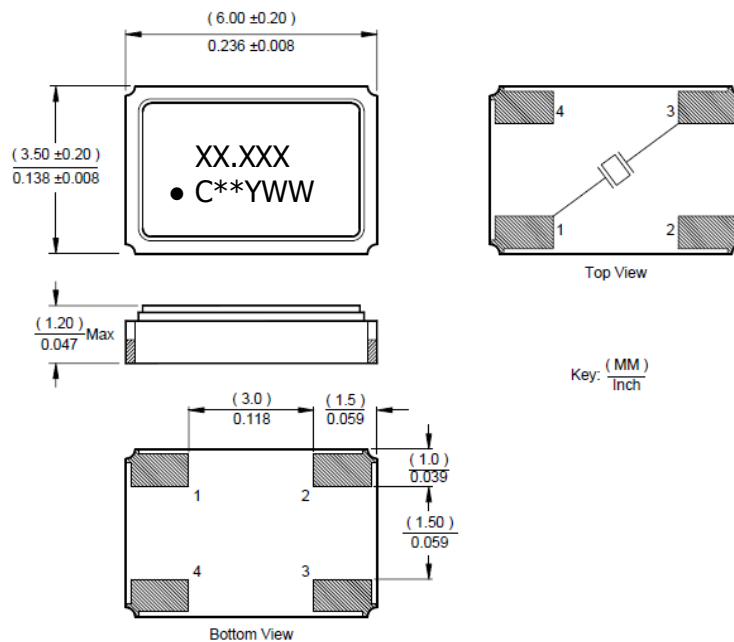

MARKING INFORMATION

1. XX.XXX – Frequency marked with 3 significant digits after the decimal.
2. C – CTS identifier.
3. ** – Manufacturing Site code.
4. YWW – Date Code, Y – Last Digit of Year, WW – Week.

NOTES

1. Complete CTS part number, frequency value and date code information must appear on reel and carton labels.
2. Termination pads (e4); barrier plating is nickel (Ni) with gold (Au) flash plate.
3. Terminations #2, #4 and metal lid are connected internally and may be connected to ground for EMI suppression.
4. MSL = 1.

SUGGESTED SOLDER PAD GEOMETRY

